

LF 1608 Series

Multilayer Chip Low-Pass Filters

Features

- ❖ Ultra small SMD type with low loss at pass-band and high attenuation at stop-band.
- ❖ RoHS compliant

Applications

- ❖ 0.5 ~6 GHz wireless communication systems.



Specifications

Part Number	Frequency Range (MHz)	Insertion Loss @ BW (dB)	Return Loss @ BW(dB)	Frequency	Attenuation (dB)
LF1608-RR83NDA_	698 ~ 960	0.45 max. @25 °C 0.6 max. @-40~105 °C	16 min.	1574 ~ 1605MHz	12 min.
				1648 ~ 1698MHz	16 min.
				1760 ~ 1830MHz	21 min.
				2472 ~ 2494MHz	30 min.
				2495 ~ 2547MHz	30 min.
				2640 ~ 2745MHz	30 min.
				3296 ~ 3396MHz	27 min.
				3520 ~ 3660MHz	27 min.
				4120 ~ 4245MHz	33 min.
				4400 ~ 4575MHz	34 min.
				4944 ~ 5094MHz	41 min.
				5280 ~ 5490MHz	32 min.
				5768 ~ 5943MHz	26 min.
				6160 ~ 6405MHz	22 min.
				6592 ~ 6792MHz	22 min.
				7040 ~ 7320MHz	19 min.
				7416 ~ 7614MHz	14 min.
7920 ~ 8235MHz	4 min.				
>8300 MHz	10 Typ.				

Q'ty/Reel (pcs) : 4,000
 Operating Temperature Range : -40 ~ +105 °C
 Storage Temperature Range : -40 ~ +105 °C
 Storage Period : 12 months max.
 Power Capacity : 3W max.

Part Number

LF 1608 - R R83 NDA □ /LF
 ① ② ③ ④ ⑤ ⑥ ⑦

① Type	LF : Low Pass Filter	② Dimensions (L x W)	1.6 x 0.8 mm
③ Material Code	R	④ Frequency Range	R83=830MHz
⑤ Specification Code	NDA	⑥ Packaging	T: Tape & Reel B: Bulk
⑦ Soldering	/LF=lead-free		

Terminal Configuration

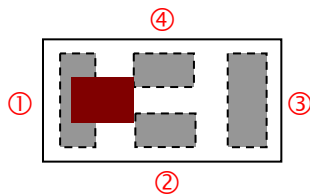

No.	Terminal Name	No.	Terminal Name
①	IN	③	OUT
②	GND	④	GND

Dimensions and Recommended PC Board Pattern

Unit : mm

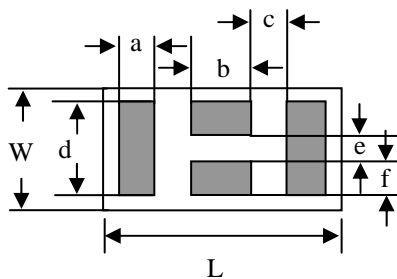

< Bottom View >

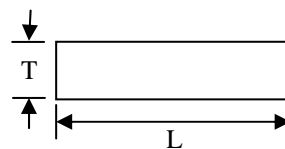

< Side View >

Mark	L	W	T	a	b	c	d	e	f
Dimensions	1.6 ± 0.15	0.8 ± 0.15	0.6 ± 0.1	0.23 ± 0.05	0.40 ± 0.1	0.30 ± 0.1	0.65 ± 0.1	0.2 ± 0.05	0.23 ± 0.05

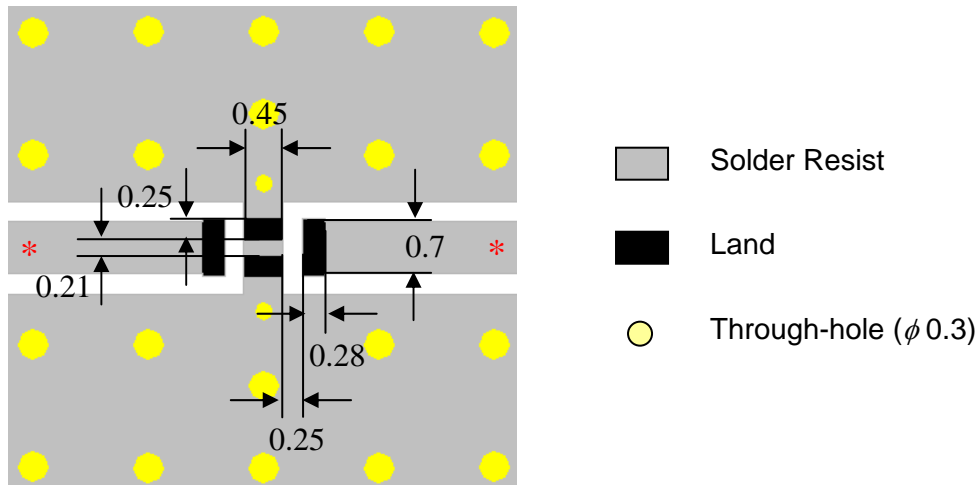

* Line width should be designed to match 50Ω characteristic impedance, depending on PCB material and thickness.

Measuring Diagram

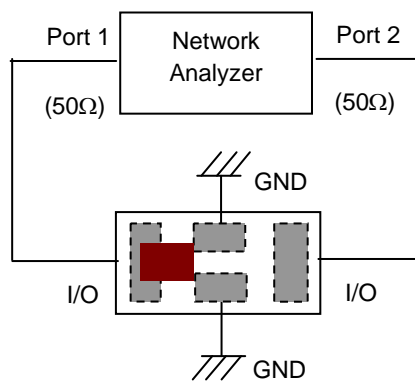

Typical Electrical Characteristics

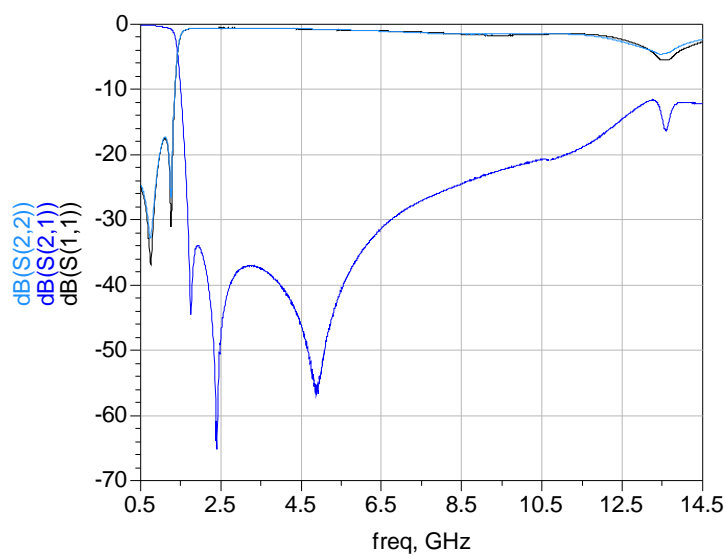

Notes

❖ The contents of this data sheet are subject to change without notice. Please confirm the specifications and delivery conditions when placing your order.

Taping Specifications

❖Tape Dimensions (Unit: mm) & Quantity

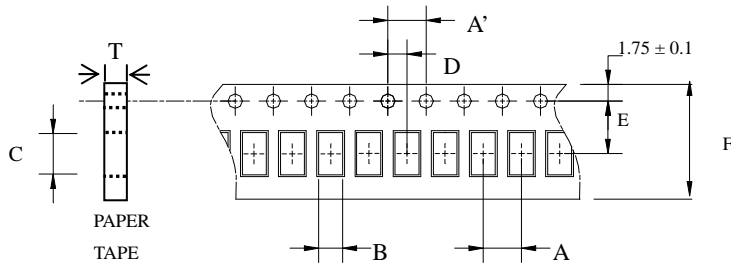

Type	A	A'	B	C	D	E	F	T	Quantity/reel	Tape material
1608	4.0± 0.1	4.0± 0.1	1.10± 0.1	1.92± 0.1	2.0± 0.1	3.5± 0.1	8.0± 0.1	0.75± 0.05	4,000pcs	Paper

❖Reel Dimensions (Unit: mm)

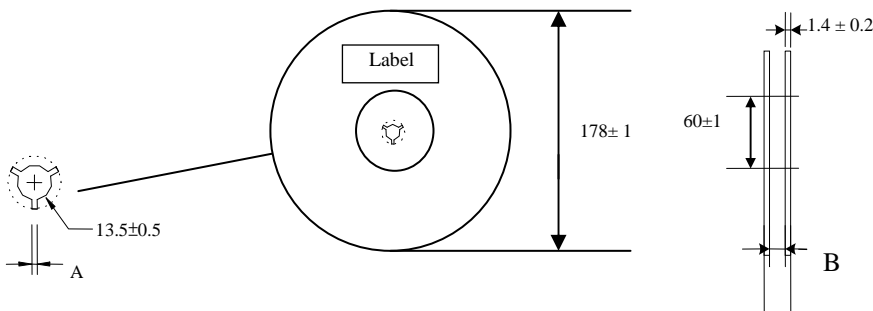

Label: Customer's Name,
ACX P/N, Q'ty, Date,
ACX Corp.

Type	A	B
1608	2.3±0.5	9.0±0.3

❖Leader and Trailer Tape

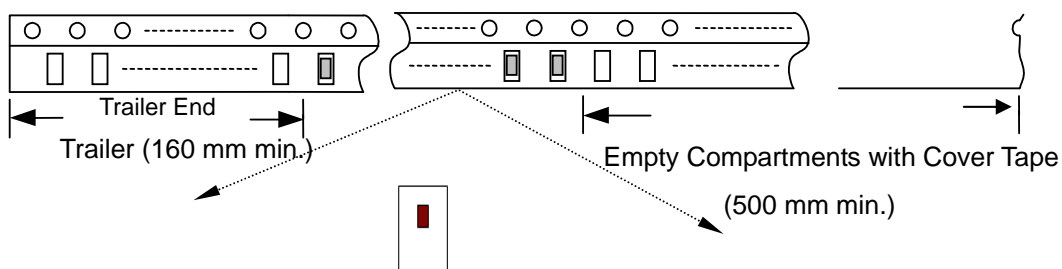

❖ **Peel-off Force**

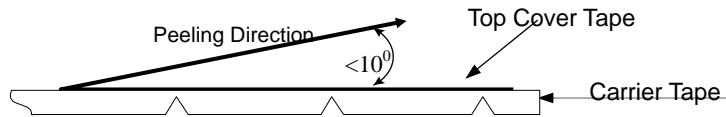

Peel-off force should be in the range of 0.1 – 0.6 N at a peel-off speed of 300 ± 10 mm/min .

❖ **Storage Conditions**

- (1) Temperature: $5 \sim 35^\circ\text{C}$, relative humidity (RH): 45~75%.
- (2) Non-corrosive environment.

Notes

- ❖ The contents of this data sheet are subject to change without notice. Please confirm the specifications and delivery conditions when placing your order.

Mechanical & Environmental Characteristics

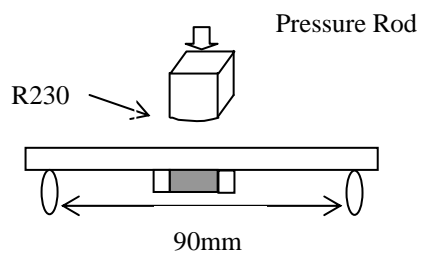
Item	Requirements	Procedure
Solderability	<ol style="list-style-type: none"> No apparent damage More than 95% of the terminal electrode shall be covered with new solder 	<ol style="list-style-type: none"> Preheat: $120 \pm 5^\circ\text{C}$ Solder: $245 \pm 5^\circ\text{C}$ for 5 ± 1 sec
Soldering strength (Termination Adhesion)	<ol style="list-style-type: none"> 5N minimum 	<ol style="list-style-type: none"> Solder specimen onto test jig. Apply push force at 0.5mm/s until electrode pads are peeled off or ceramic are broken. Pushing force is applied to longitude direction
Deflection (Substrate Bending)	<ol style="list-style-type: none"> No apparent damage 	<ol style="list-style-type: none"> Solder specimen onto test jig (FR4, 1.6mm) using the recommend soldering profile. Apply a bending force of 2mm deflection. 
Heat/Humidity Resistance	<ol style="list-style-type: none"> No apparent damage Fulfill the electrical specification after test 	<ol style="list-style-type: none"> Temperature: $85 \pm 2^\circ\text{C}$ Humidity: 90% ~ 95% RH Duration: 1000 ± 48hrs Recovery: 1-2hrs
Thermal shock (Temperature Cycle)	<ol style="list-style-type: none"> No apparent damage Fulfill the electrical specification after test 	<ol style="list-style-type: none"> One cycle/step 1 : $125 \pm 5^\circ\text{C}$ for 30 min step 2 : $-40 \pm 5^\circ\text{C}$ for 30 min No of cycles : 100 Recovery: 1-2 hrs
Low Temperature Resistance	<ol style="list-style-type: none"> No apparent damage Fulfill the electrical specification after test 	<ol style="list-style-type: none"> Temperature: $-40 \pm 5^\circ\text{C}$ Duration: 500 ± 24hrs Recovery: 1-2hrs

Soldering Conditions

❖ Typical Soldering Profile for Lead-free Process

Reflow Soldering :

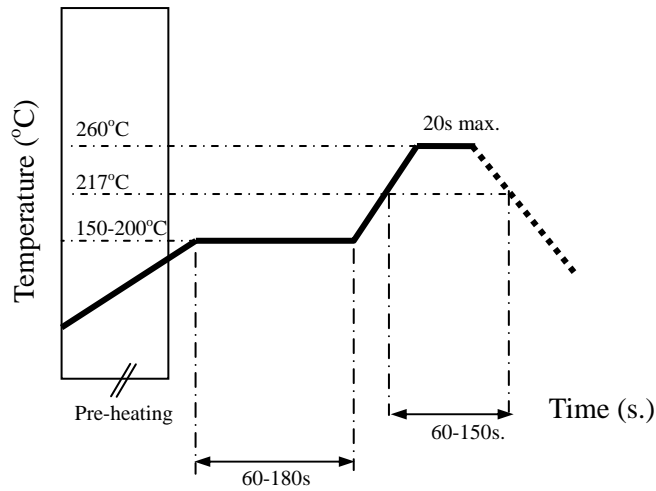

Notes

- ❖ The contents of this data sheet are subject to change without notice. Please confirm the specifications and delivery conditions when placing your order.

Advanced Ceramic X Corp.

16 Tzu Chiang Road, Hsinchu Industrial District Hsinchu Hsien 303, Taiwan

TEL:886-3-5987008 FAX:886-3-5987001

E-mail: acx@acxc.com.tw

<http://www.acxc.com.tw>