

# DP 1608 Series

## Multilayer Chip Diplexers

### Features

- ❖ Monolithic structure including one low-pass and one band-pass filters with loss pole at adjacent passband.
- ❖ RoHS compliant.

### Applications

- ❖ Dual-band / dual-mode 2.4GHz/5-7GHz WLAN.

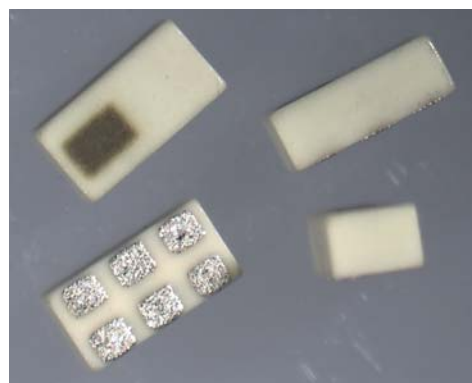

### Specifications

Part Number	Passband (MHz)	Insertion Loss (dB)	VSWR	Attenuation (dB)	Isolation (dB)
<b>DP1608-R2460MNQ2</b>	2400~2500	0.8 max. / 0.6 typ. @ 25°C 1.0 max. / 0.8 typ. @ 105°C	2.0 max.	45 min. / 50 typ. @4800~5000MHz 15 min. / 33 typ. @7200~7500MHz	40 min. / 50 typ. @2400~2500MHz 40 min. / 50 typ. @4800~5000MHz
	4900~5100	1.3 max. / 1.0 typ. @ 25°C 1.5 max. / 1.2 typ. @ 105°C	2.0 max.	40 min. / 50 typ. @2400~2500MHz	40 min. / 45 typ. @5000~6000MHz
	5150~5950	1.0max. / 0.8 typ. @ 25°C 1.2max. / 1.0 typ. @ 105°C		22 min. / 25 typ. @10300~14300MHz	30 min. / 35 typ. @6000~7150MHz
	5950~7150	1.0max. / 0.8 typ. @ 25°C 1.2max. / 1.0 typ. @ 105°C		15 min. / 25 typ. @15300~21450MHz	

Q'ty/Reel (pcs) : 4000  
 Operating Temperature Range : -40 ~ +105 °C  
 Storage Temperature Range : -40 ~ +105 °C  
 Storage Period : 12 months max.  
 Power Capacity : 3W max.

### Part Number

DP   1608   -   R   2460   MNQ2   □   /LF  
 ①   ②   ③   ④   ⑤   ⑥   ⑦

① Type	DP : Diplexer	② Dimensions (L x W)	1.6 x 0.8 mm
③ Material Code	R	④ Frequency Range	2460=2400MHz/6000MHz
⑤ Specification Code	MNQ2	⑥ Packaging	T: Tape & Reel B: Bulk
⑦ Soldering	/LF=lead-free		

## Terminal Configuration

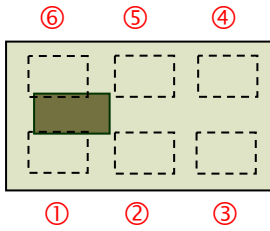

No.	Terminal Name	No.	Terminal Name
①	GND	④	Lower Freq. Port
②	Common Port	⑤	GND
③	GND	⑥	Higher Freq. Port

## Dimensions

Unit : mm

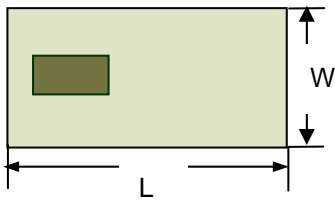

<Top View>

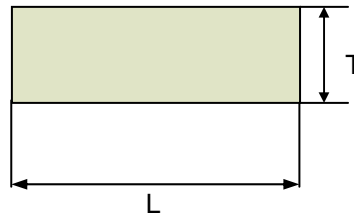

<Side View>

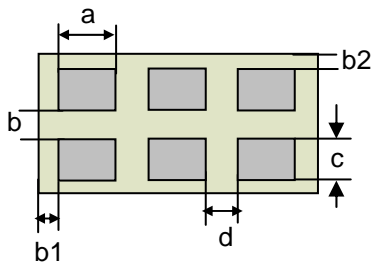

<Bottom View>

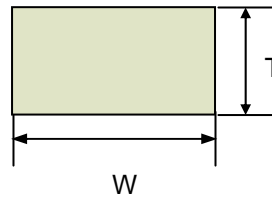

<Side View>

Mark	L	W	T	a	b	c	d	b1	b2
Dimensions	1.6 ±0.1	0.8 ±0.1	0.7 max.	0.3 ±0.1	0.2 ±0.1	0.25 ±0.1	0.2 ±0.1	0.15 ±0.05	0.05 ±0.05

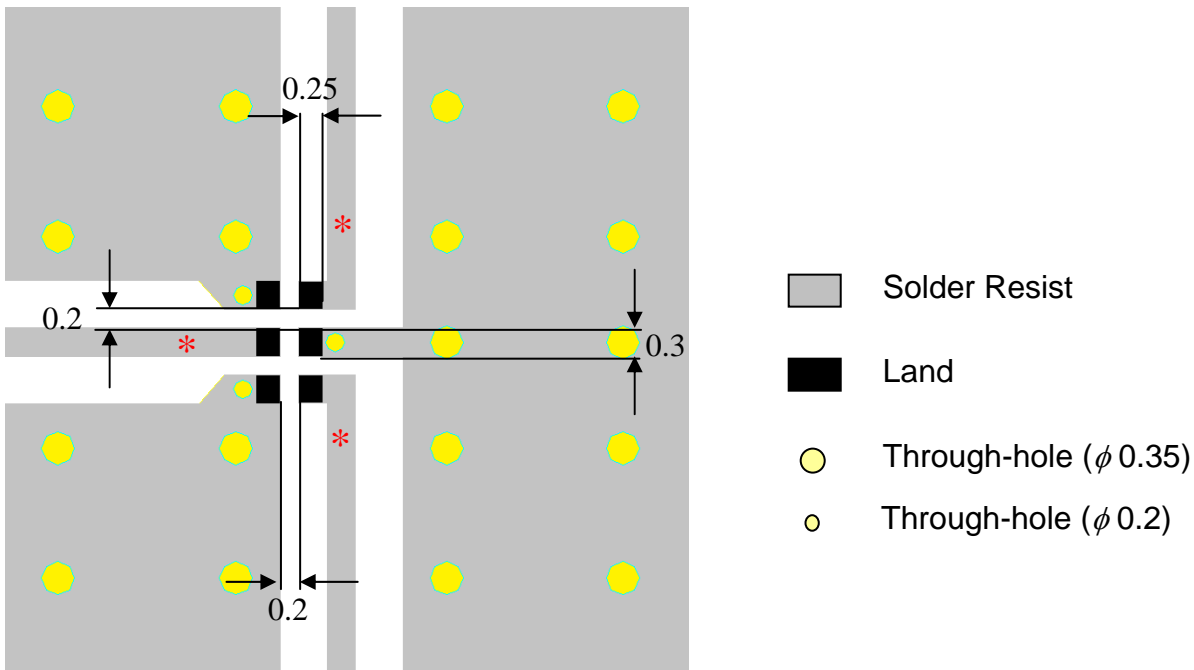

\* Line width should be designed to match 50ohm characteristic impedance, depending on PCB material and thickness.

### Measuring Diagram

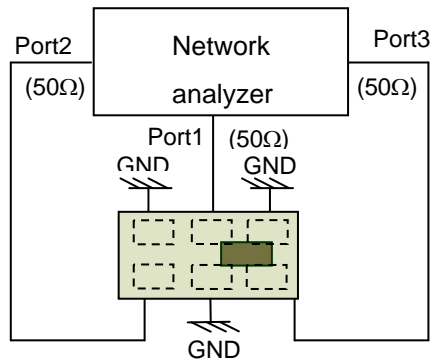

**Typical Electrical Characteristics (T=25°C)**

**Attenuation**

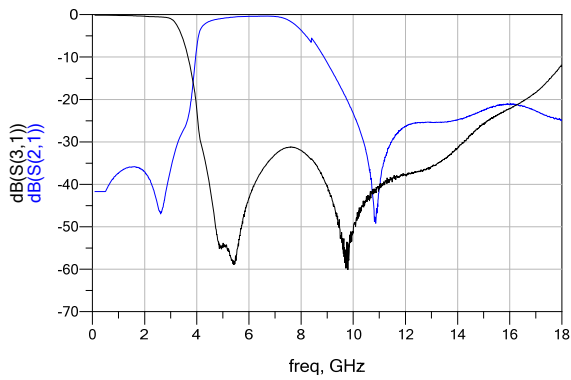

**Return Loss**

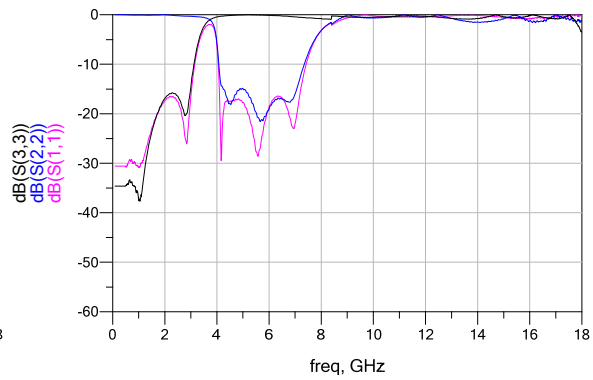

**Isolation**

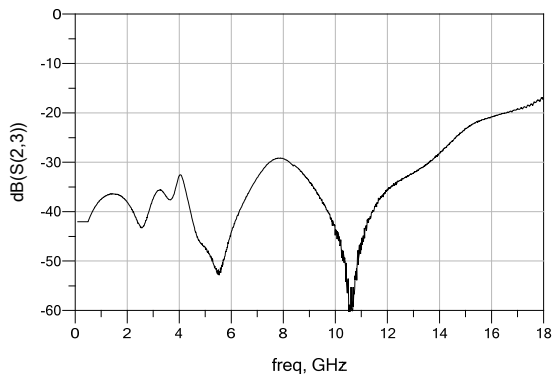

**Notes**

- ❖ The contents of this data sheet are subject to change without notice. Please confirm the specifications and delivery conditions when placing your order.

## Taping Specifications

### ❖Tape Dimensions (Unit: mm) & Quantity

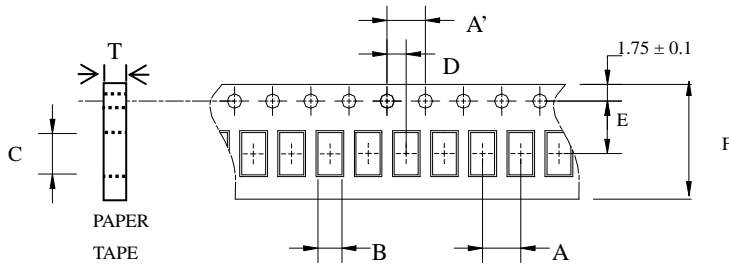

Type	A	A'	B	C	D	E	F	T	Quantity/reel	Tape material
1608	4.0±	4.0±	1.10±	1.92±	2.0±	3.5±	8.0±	0.75±	4,000pcs	Paper
	0.1	0.1	0.1	0.1	0.1	0.1	0.1	0.05		

### ❖Reel Dimensions (Unit: mm)

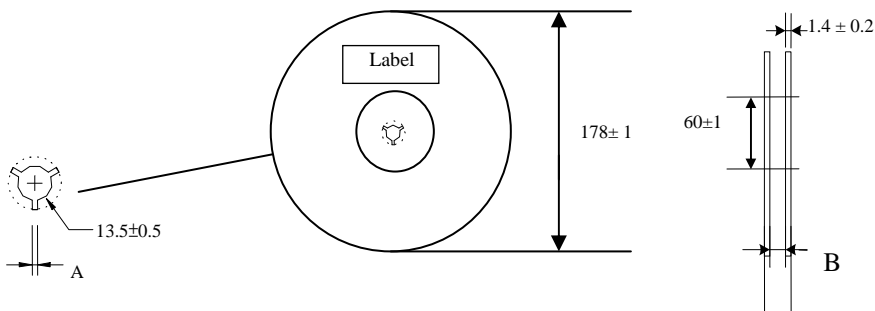

Label: Customer's Name,  
ACX P/N, Q'ty, Date,  
ACX Corp.

Type	A	B
1608	2.3±0.5	9.0±0.3

### ❖Leader and Trailer Tape

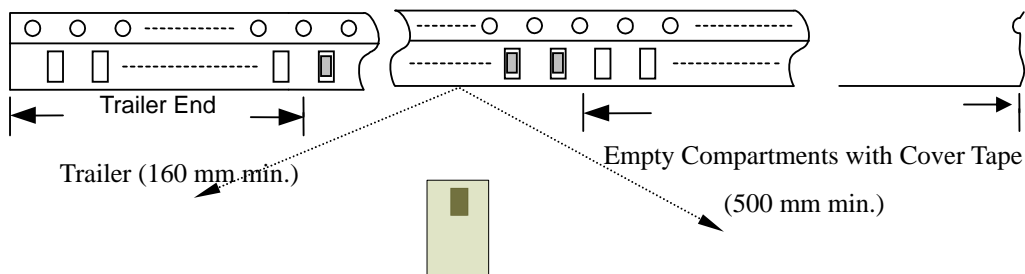

❖ **Peel-off Force**

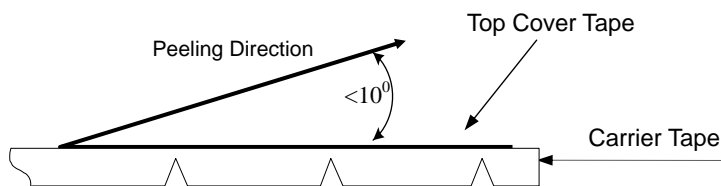

Peel-off force should be in the range of 0.1 – 0.6 N at a peel-off speed of  $300 \pm 10$  mm/min .

❖ **Storage Conditions**

- (1) Temperature: 5 ~35°C , relative humidity (RH): 45~75%.
- (2) Non-corrosive environment.

**Notes**

- ❖ The contents of this data sheet are subject to change without notice. Please confirm the specifications and delivery conditions when placing your order.

## Mechanical & Environmental Characteristics

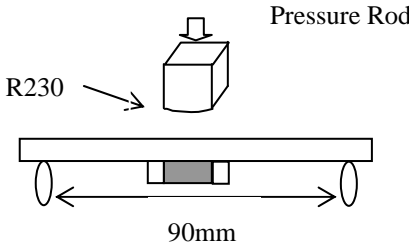
Item	Requirements	Procedure
Solderability	<ol style="list-style-type: none"> <li>No apparent damage</li> <li>More than 95% of the terminal electrode shall be covered with new solder</li> </ol>	<ol style="list-style-type: none"> <li>Preheat: <math>120 \pm 5^\circ\text{C}</math></li> <li>Solder: <math>245 \pm 5^\circ\text{C}</math> for <math>5 \pm 1</math> sec</li> </ol>
Soldering strength (Termination Adhesion)	<ol style="list-style-type: none"> <li>5N minimum</li> </ol>	<ol style="list-style-type: none"> <li>Solder specimen onto test jig.</li> <li>Apply push force at 0.5mm/s until electrode pads are peeled off or ceramic are broken. Pushing force is applied to longitude direction</li> </ol>
Deflection (Substrate Bending)	<ol style="list-style-type: none"> <li>No apparent damage</li> </ol>	<ol style="list-style-type: none"> <li>Solder specimen onto test jig (FR4, 1.6mm) using the recommend soldering profile.</li> <li>Apply a bending force of 2mm deflection.</li> </ol> 
Heat/Humidity Resistance	<ol style="list-style-type: none"> <li>No apparent damage</li> <li>Fulfill the electrical specification after test</li> </ol>	<ol style="list-style-type: none"> <li>Temperature: <math>85 \pm 2^\circ\text{C}</math></li> <li>Humidity: 90% ~ 95% RH</li> <li>Duration: <math>1000 \pm 48</math>hrs</li> <li>Recovery: 1-2hrs</li> </ol>
Thermal shock (Temperature Cycle)	<ol style="list-style-type: none"> <li>No apparent damage</li> <li>Fulfill the electrical specification after test</li> </ol>	<ol style="list-style-type: none"> <li>One cycle/step 1 : <math>125 \pm 5^\circ\text{C}</math> for 30 min step 2 : <math>-40 \pm 5^\circ\text{C}</math> for 30 min</li> <li>No of cycles : 100</li> <li>Recovery: 1-2 hrs</li> </ol>
Low Temperature Resistance	<ol style="list-style-type: none"> <li>No apparent damage</li> <li>Fulfill the electrical specification after test</li> </ol>	<ol style="list-style-type: none"> <li>Temperature: <math>-40 \pm 5^\circ\text{C}</math></li> <li>Duration: <math>500 \pm 24</math>hrs</li> <li>Recovery: 1-2hrs</li> </ol>

## Soldering Conditions

### ❖ Typical Soldering Profile for Lead-free Process

Reflow Soldering :

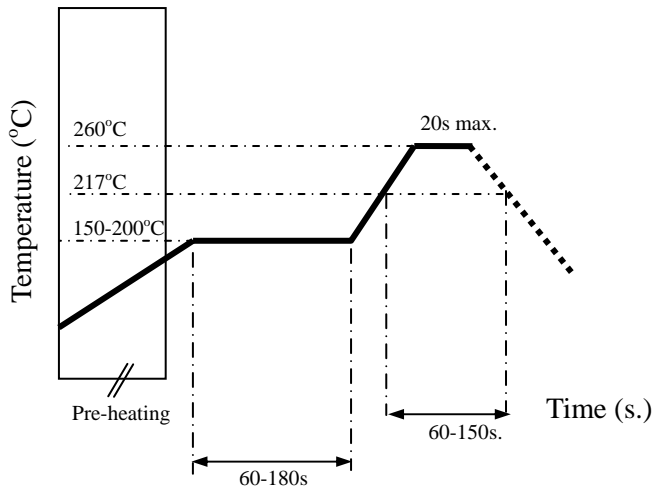

## Notes

- ❖ The contents of this data sheet are subject to change without notice. Please confirm the specifications and delivery conditions when placing your order.

### **Advanced Ceramic X Corp.**

16 Tzu Chiang Road, Hsinchu Industrial District Hsinchu Hsien 303, Taiwan

TEL:886-3-5987008 FAX:886-3-5987001

E-mail: [acx@acxc.com.tw](mailto:acx@acxc.com.tw)

<http://www.acxc.com.tw>