

ATR151 Series

Multilayer Chip Antenna

Features

- ❖ Monolithic SMD with small, low-profile and light-weight type.
- ❖ Wide bandwidth, RoHS compliant

Applications

- ❖ RF modules for 900MHz band.



Specifications

Part Number	Operating Frequency (MHz)	Peak Gain (XZ-V)	Average Gain (XZ-V)	VSWR	Impedance
ATR151 -BR90MAA_	880~960	-0.7dBi typ.	-2.6 dBi typ.	2.2 max.	50 Ω

Q'ty/Reel (pcs) : 1000 pcs
 Operating Temperature Range : -40 ~ +85 °C
 Storage Temperature Range : -40 ~ +85 °C
 Storage Period : 12 months max.
 Power Capacity : 2W max.

Part Number

AT R151 - B R90 MAA □ /LF
 ① ② ③ ④ ⑤ ⑥ ⑦

① Type	AT : Antenna	② Dimensions (L x W)	11× 5.1 mm
③ Material Code	B	④ Initial center frequency	R90=900MHz
⑤ Specification Code	MAA	⑥ Packaging	T: Tape & Reel B: Bulk
⑦ Soldering	=lead-containing /LF=lead-free		

Terminal Configuration

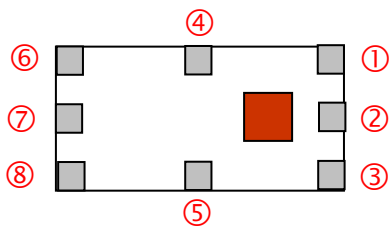

No.	Terminal Name	No.	Terminal Name
①	NC	⑤	NC
②	Feed Point	⑥	NC
③	NC	⑦	NC
④	NC	⑧	NC

Dimensions and Recommended PC Board Pattern

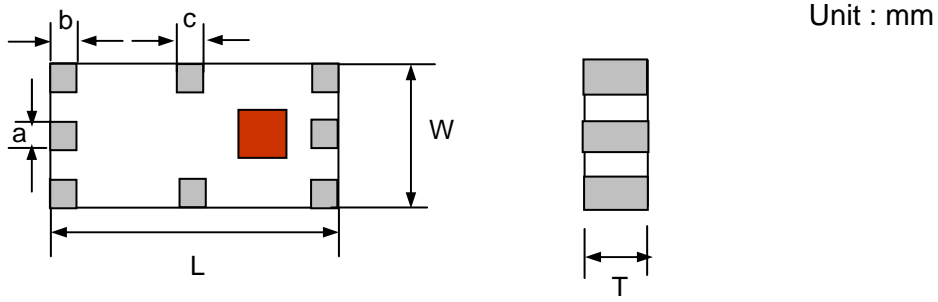

Mark	L	W	T	a	b	c
Dimensions	11.0 ±0.3	5.1 ±0.3	1.5 ±0.2	1.0 ±0.2	0.5 ±0.3	0.5 ±0.3

(a) Without Matching Circuits

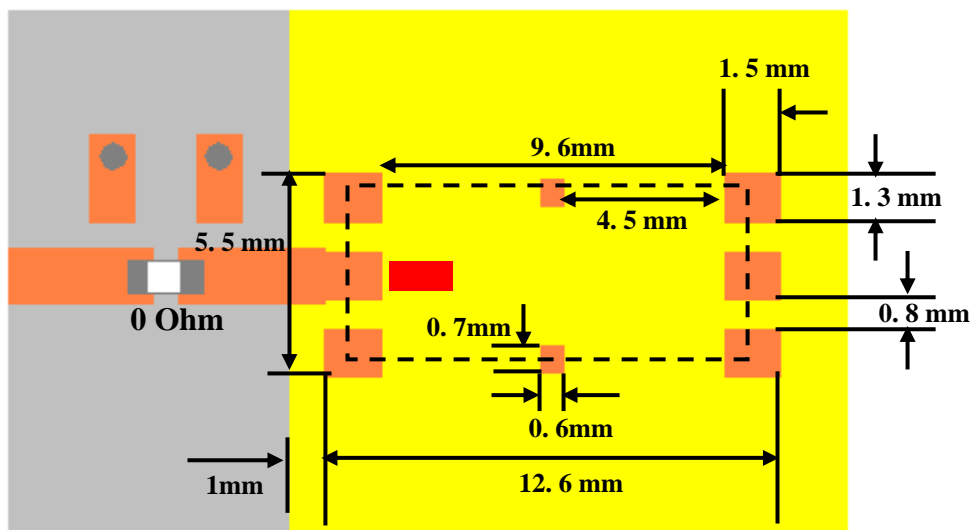

(b) With Matching Circuits

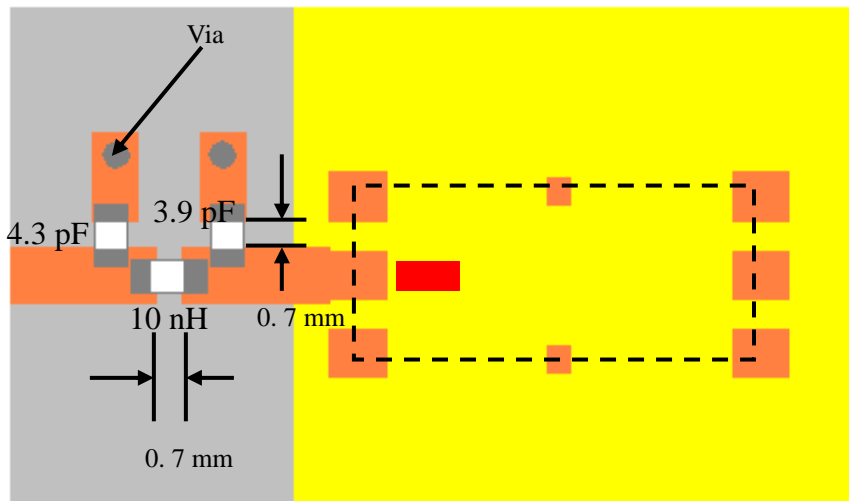

*Line width should be designed to match 50Ω characteristic impedance, depending on PCB material and thickness.

Typical Electrical Characteristics (T=25°C)

❖ Test Board

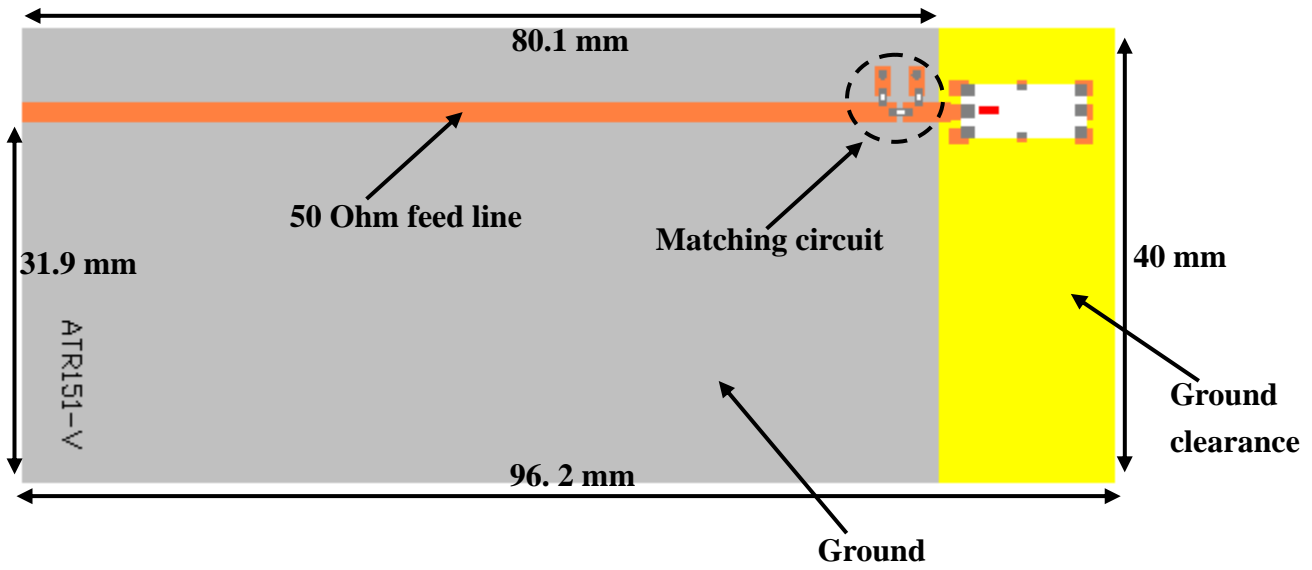

❖ Return Loss

(a) Without Matching Circuit

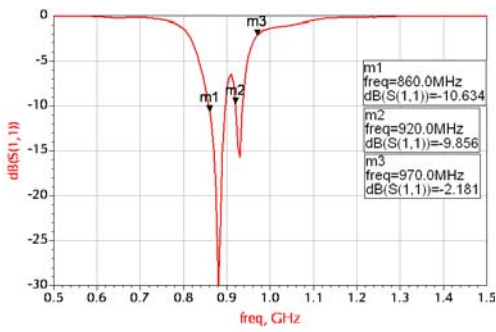

(b) With Matching Circuits

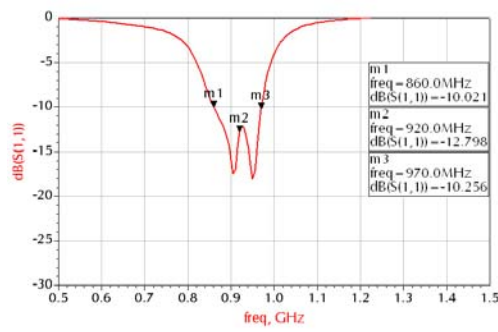

❖ Smith chard

(a) Without Matching Circuit

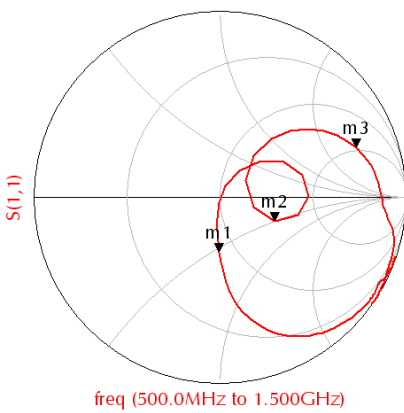

(b) With Matching Circuits

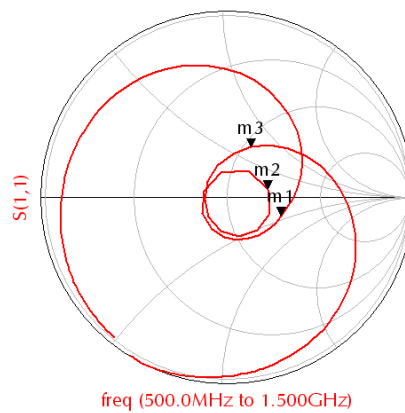

❖ Radiation Patterns

XY-V/XY-H

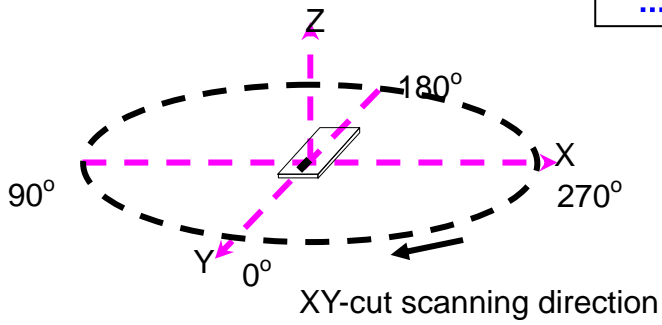

XY cut @920MHz
— Vertical
⋯ Horizontal

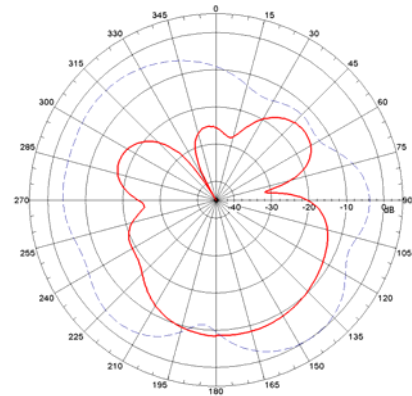

XZ-V/XZ-H

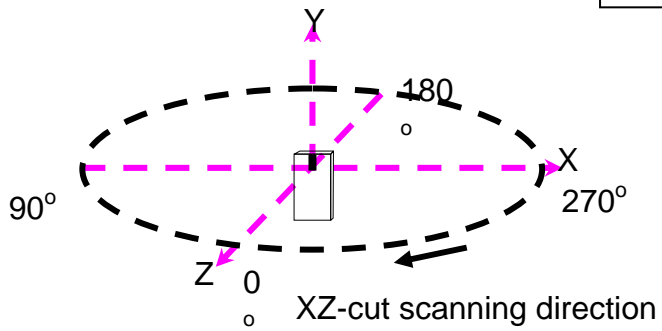

XZ cut @920MHz
— Vertical
⋯ Horizontal

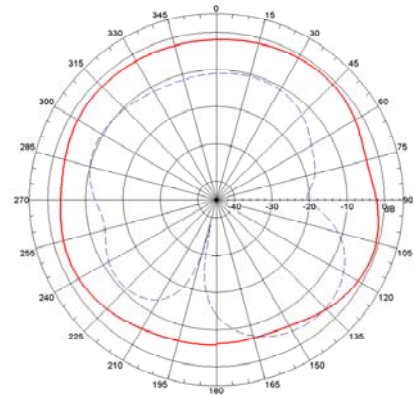

YZ-V/YZ-H

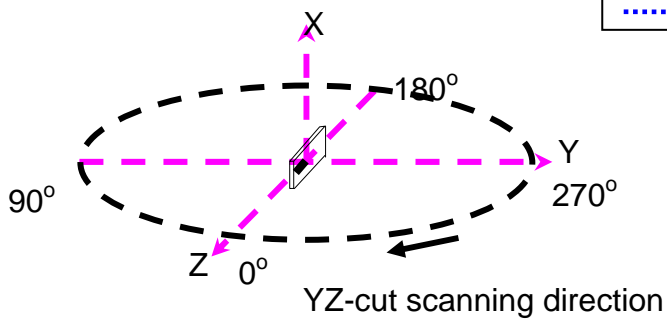

YZ cut @920MHz
— Vertical
⋯ Horizontal

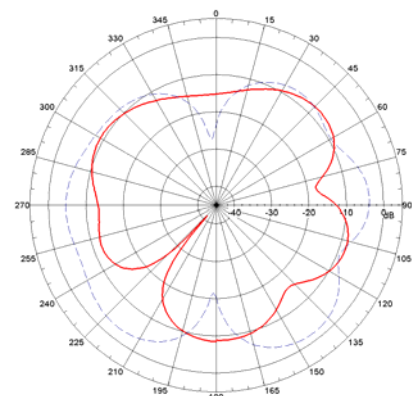

Taping Specifications

❖Tape & Reel Dimensions (Unit: mm) vs. Quantity (pcs)

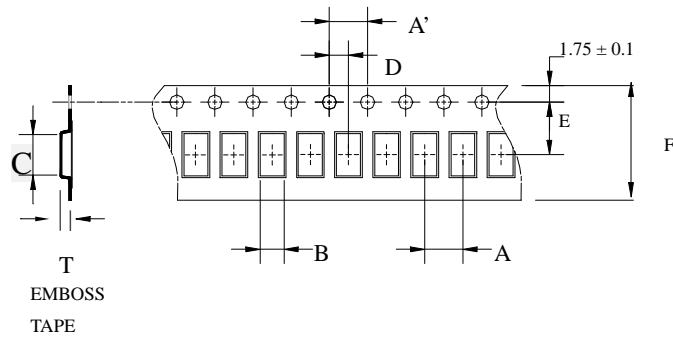

Type	A	A'	B	C	D	E	F	T	Quantity/per reel	Tape material
ATR151	8.0±	4.0±	5.3±	11.30±	2.0±	11.5±	24.0±	1.75±	1,000pcs	Plastic (Embossed)
	0.1	0.1	0.1	0.1	0.05	0.1	0.3	0.1		

❖Reel Dimensions (Unit: mm)

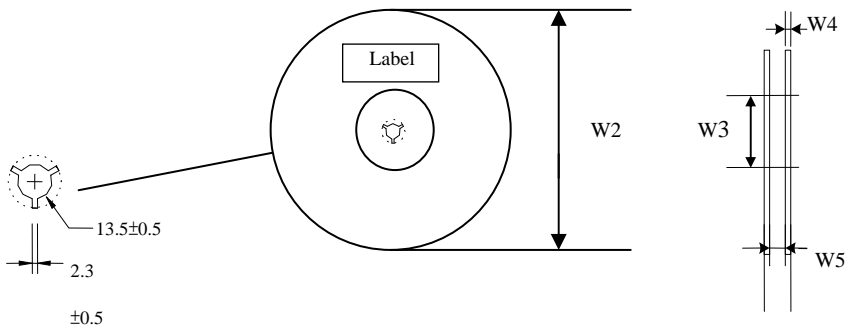

Label: Customer's Name,
ACX P/N, Q'ty, Date,
ACX Corp.

Type	W2	W3	W4	W5	Material No.
ATR151	178±1	60±1	1.4±0.2	25±0.5	1220302

❖Leader and Trailer Tape

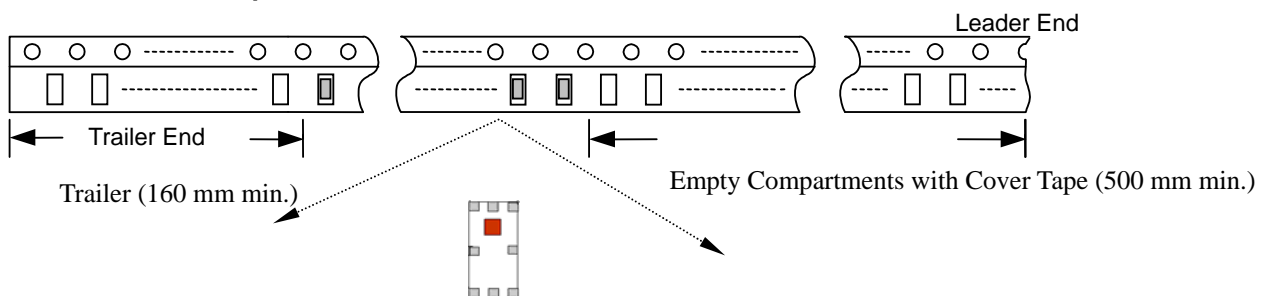

❖ **Peel-off Force**

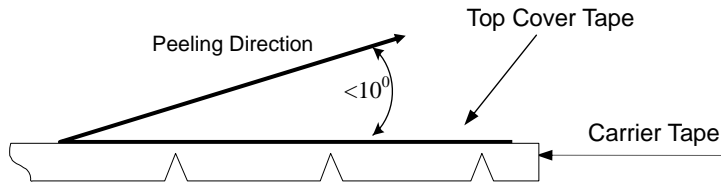

Peel-off force should be in the range of 0.2 – 1.20 N at a peel-off speed of 300 ± 10 mm/min .

❖ **Storage Conditions**

- (1) Temperature: 5 ~35°C , relative humidity (RH): 45~75%.
- (2) Non-corrosive environment

Notes

❖ The contents of this data sheet are subject to change without notice. Please confirm the specifications and delivery conditions when placing your order.

Mechanical & Environmental Characteristics

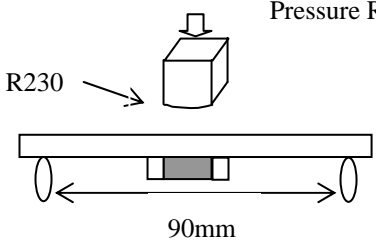
Item	Requirements	Procedure
Solderability	<ol style="list-style-type: none"> No apparent damage More than 95% of the terminal electrode shall be covered with new solder 	<ol style="list-style-type: none"> Preheat: $120 \pm 5^\circ\text{C}$ Solder: $245 \pm 5^\circ\text{C}$ for 5 ± 1 sec
Soldering strength (Termination Adhesion)	<ol style="list-style-type: none"> 1kg minimum 	<ol style="list-style-type: none"> Solder specimen onto test jig. Apply push force at 0.5mm/s until electrode pads are peeled off or ceramic are broken. Pushing force is applied to longitude direction
Deflection (Substrate Bending)	<ol style="list-style-type: none"> No apparent damage 	<ol style="list-style-type: none"> Solder specimen onto test jig (FR4, 0.8mm) using the recommend soldering profile. Apply a bending force of 1mm deflection 
Heat/Humidity Resistance	<ol style="list-style-type: none"> No apparent damage Fulfill the electrical specification after test 	<ol style="list-style-type: none"> Temperature: $85 \pm 2^\circ\text{C}$ Humidity: 90% ~ 95% RH Duration: 1000 ± 48hrs Recovery: 1-2hrs
Thermal shock (Temperature Cycle)	<ol style="list-style-type: none"> No apparent damage Fulfill the electrical specification after test 	<ol style="list-style-type: none"> One cycle/step 1 : $125 \pm 5^\circ\text{C}$ for 30 min step 2 : $-40 \pm 5^\circ\text{C}$ for 30 min No of cycles : 100 Recovery: 1-2 hrs
Low Temperature Resistance	<ol style="list-style-type: none"> No apparent damage Fulfill the electrical specification after test 	<ol style="list-style-type: none"> Temperature: $-40 \pm 5^\circ\text{C}$ Duration: 500 ± 24hrs Recovery: 1-2hrs

Soldering Conditions

❖ Typical Soldering Profile for Lead-free Process

Reflow Soldering :

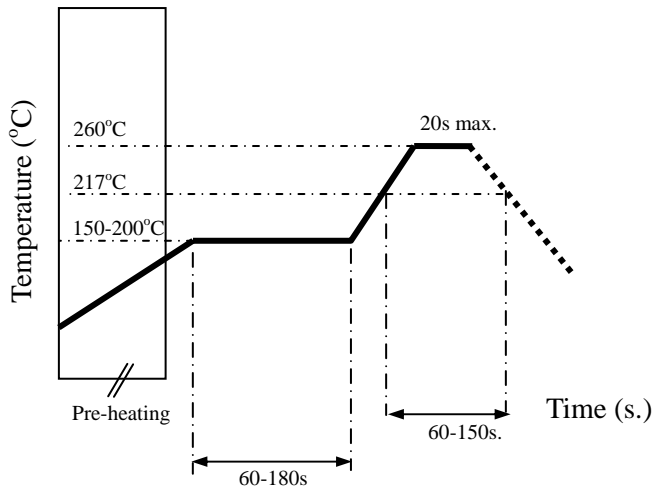

Notes

❖ The contents of this data sheet are subject to change without notice. Please confirm the specifications and delivery conditions when placing your order.

Advanced Ceramic X Corp.

16 Tzu Chiang Road, Hsinchu Industrial District Hsinchu Hsien 303, Taiwan

TEL:886-3-5987008 FAX:886-3-5987001

E-mail: acx@acxc.com.tw

<http://www.acxc.com.tw>