

AD8516 Series

Multilayer Chip Antenna

Features

- ❖ Monolithic SMD with small, low-profile and light-weight type.
- ❖ Wide bandwidth
- ❖ Easier impedance matching on PCB by using two feed lines
- ❖ RoHS compliant

Applications

- ❖ Dual-band 2.4/5.5 GHz WLAN



Specifications

Part Number	Frequency Range (MHz)	Peak Gain	Average Gain	VSWR	Impedance
AD8516-A2455AA_	2400~2500	2.0 dBi typ. (XZ-Total)	-0.5 dBi typ. (XZ- Total)	2.2 max.	50 Ω
	4900~5875	1.5 dBi typ. (YZ- Total)	-1.0 dBi typ. (YZ- Total)	2.2 max.	50 Ω

Q'ty/Reel (pcs) : 1000pcs
 Operating Temperature Range : -40 ~ +85 °C
 Storage Temperature Range : -40 ~ +85 °C
 Storage Period : 12 months max.
 Power Capacity : 2W max.

Part Number

AD 8516 - A 2455 AA □ □
 ① ② ③ ④ ⑤ ⑥ ⑦

① Type	AD : Dual-band Antenna	② Dimensions (L x W)	8.5x 1.6 mm
③ Material Code	A	④ Frequency Range	2455=2400/5500 MHz
⑤ Specification Code	AA	⑥ Packaging	T: Tape & Reel B: Bulk
⑦ Soldering	/LF=lead-free		

Terminal Configuration

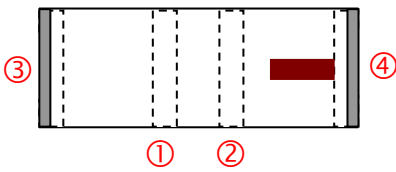

No.	Terminal Name	No.	Terminal Name
①	Feeding Point for High Band	②	Feeding Point for Low Band
③	NC	④	NC

Dimensions and Recommended PC Board Pattern

Unit : mm

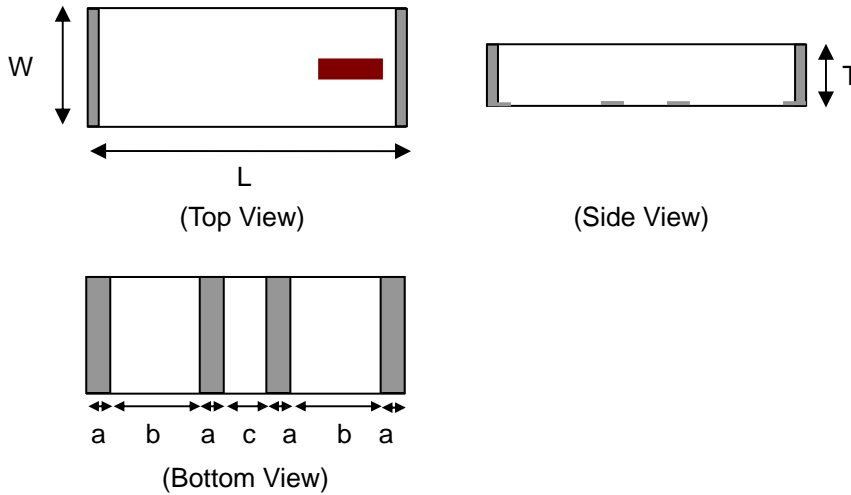

Mark	L	W	T	a	b	c
Dimensions	8.5±0.2	1.6±0.2	1.2+ 0.1/-0.2	0.51±0.15	2.64±0.15	1.18±0.15

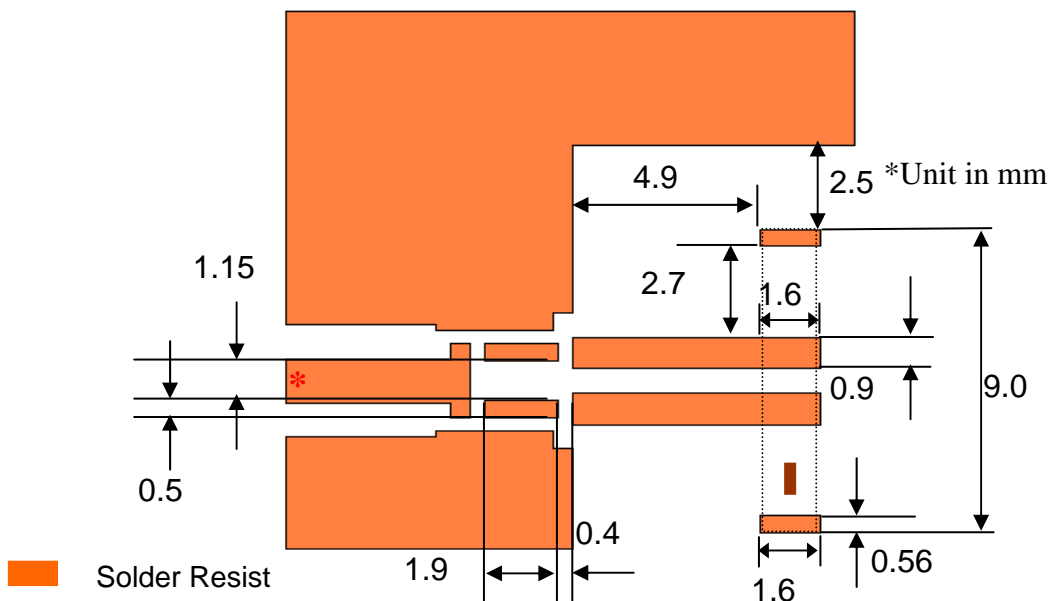

*Line width should be designed to match 50Ω characteristic impedance, depending on PCB material and thickness.

Typical Electrical Characteristics (T=25°C)

❖ Test Board

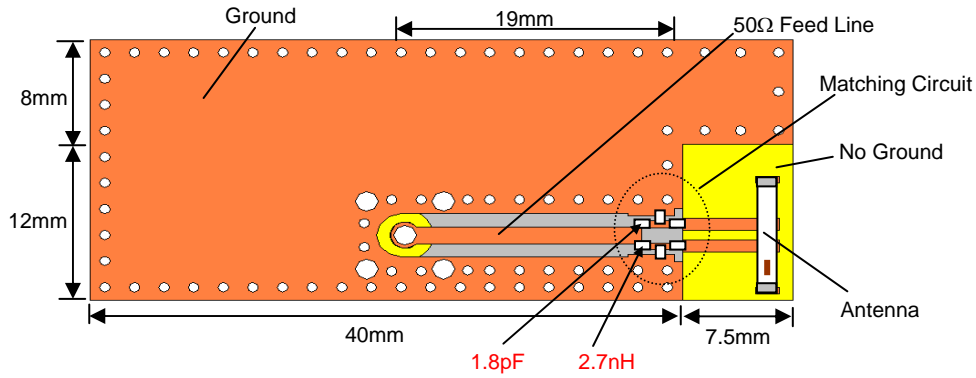

❖ Return circuits)

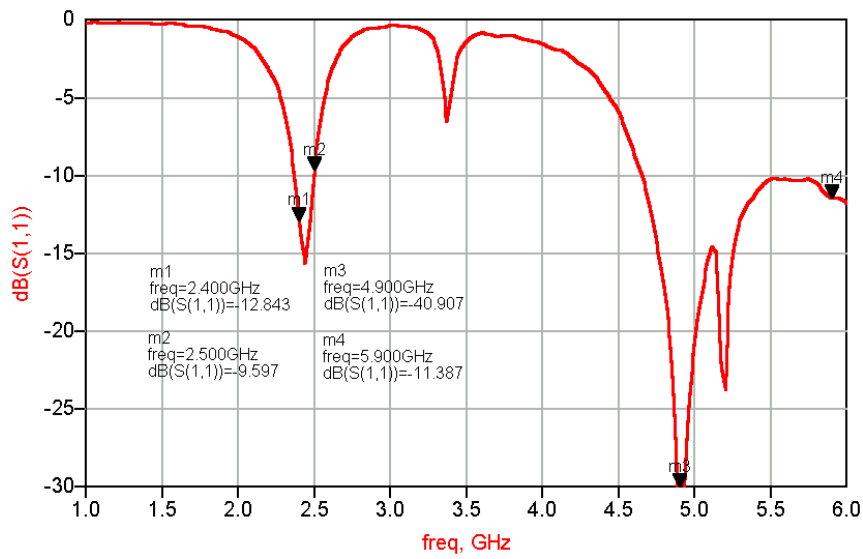

Loss (with matching)

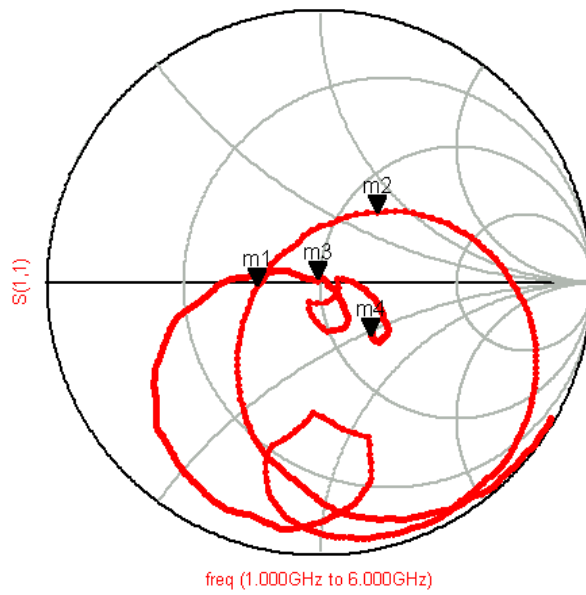

❖ **Radiation Patterns @2450MHz**

(Antenna Efficiency: 2400 / 2450 / 2500MHz: 76 / 75 / 67%)

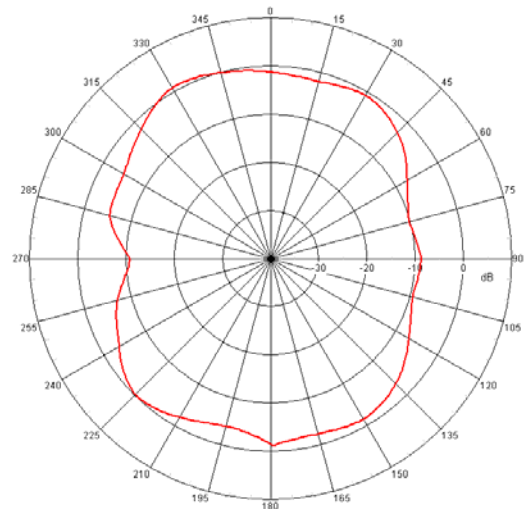
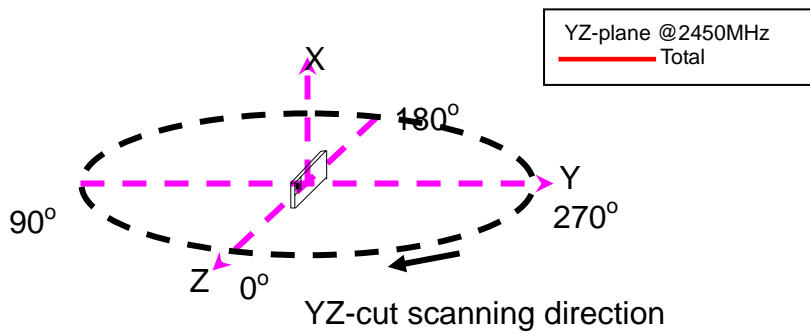
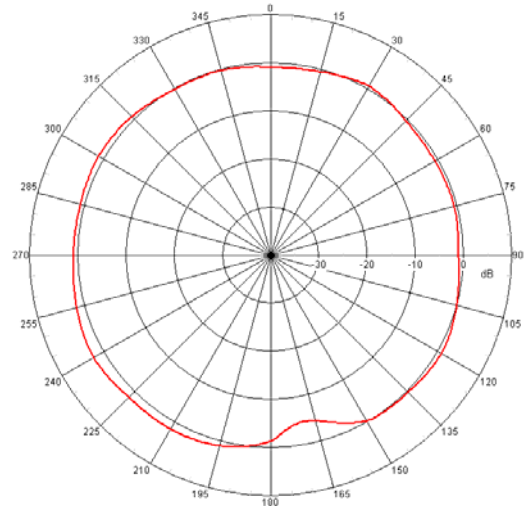
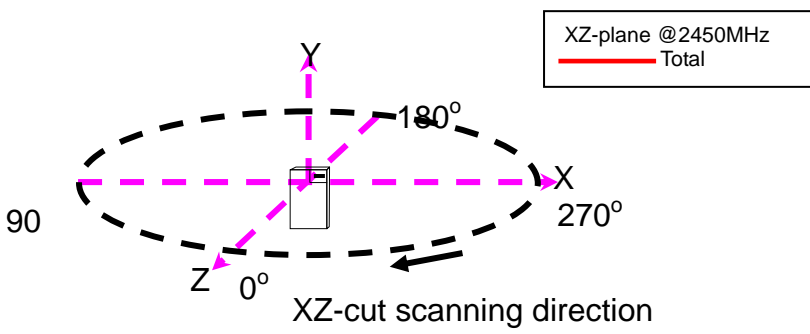
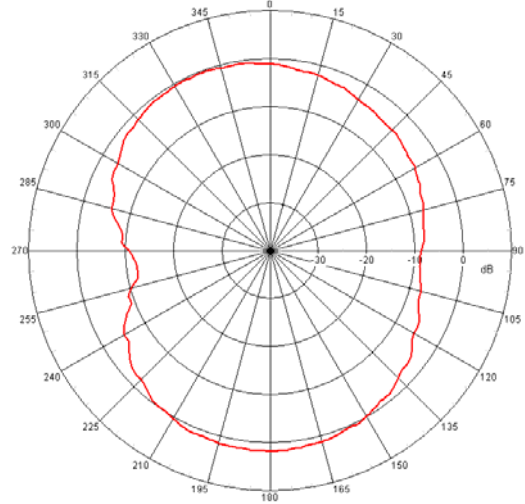
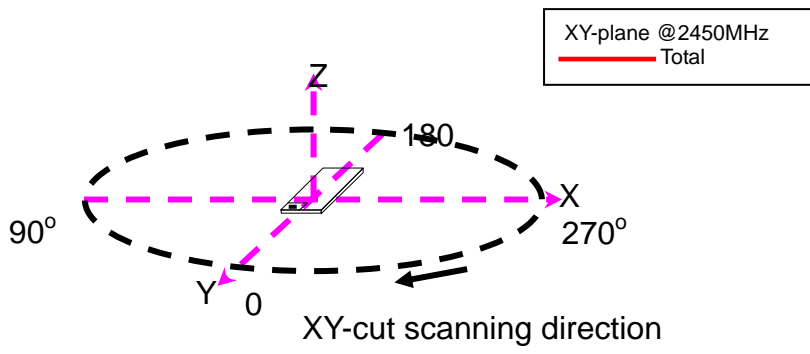

❖ **Radiation Patterns @5500MHz**

(Antenna Efficiency: 4900 / 5500 / 5875MHz: 81 / 85 / 80%)

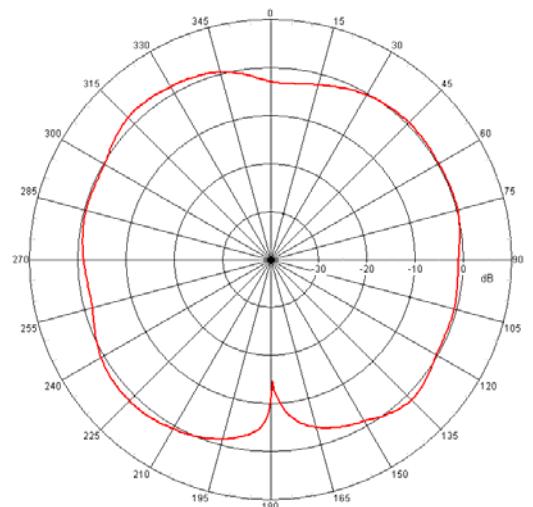
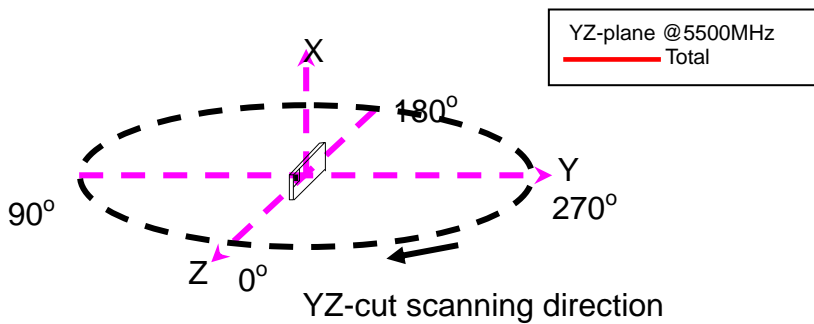
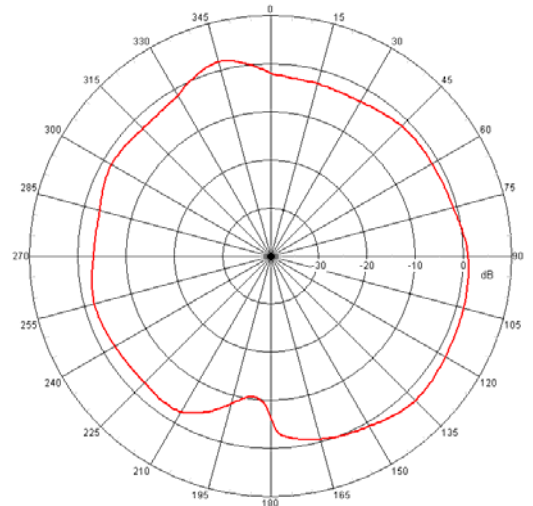
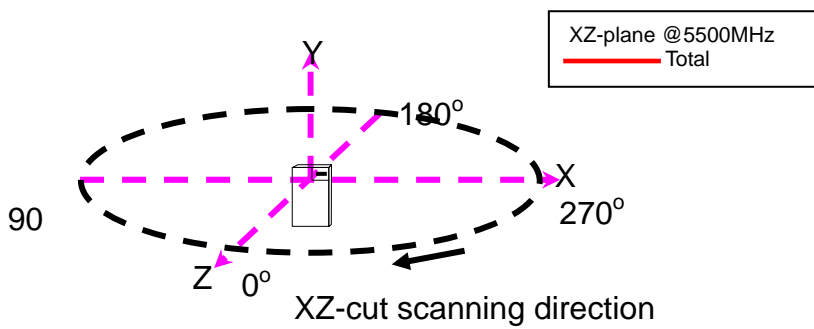
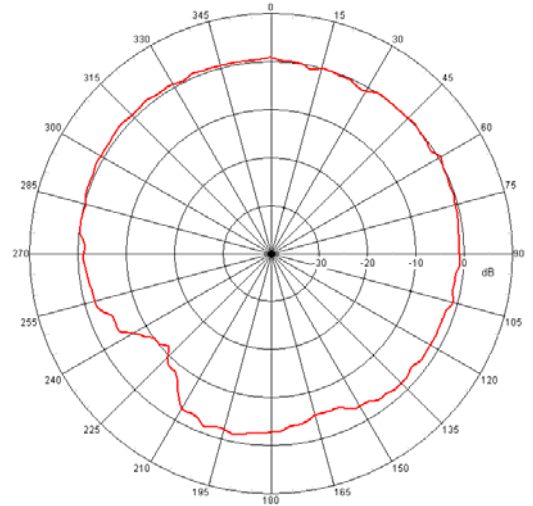
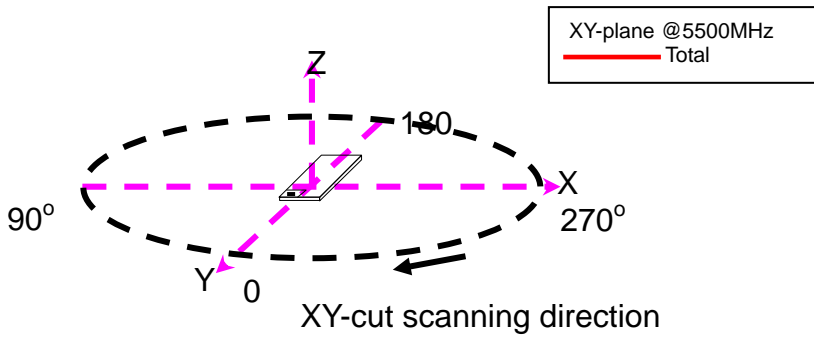

Taping Specifications

❖Tape & Reel Dimensions (Unit: mm) vs. Quantity (pcs)

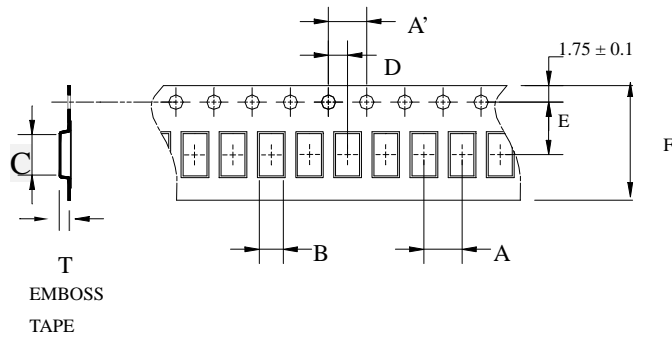

Type	A	A'	B	C	D	E	F	T	Quantity/per reel	Tape material
AD8516	4.0±	4.0±	1.85±	8.70±	2.0±	7.5±	16.0±	1.40±	1,000pcs	Plastic (Embossed)
	0.1	0.1	0.1	0.1	0.05	0.1	0.2	0.1		

❖Reel Dimensions (Unit: mm)

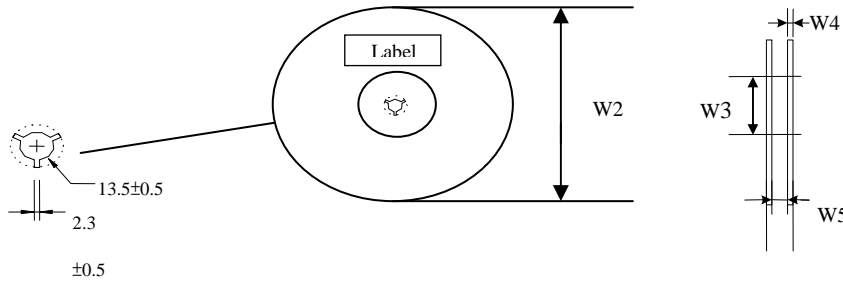

Label: Customer's Name,
ACX P/N, Q'ty, Date,
ACX Corp

Type	W2	W3	W4	W5
AD8516	178±1	60±1	1.4±0.2	17±0.5

❖Leader and Trailer Tape

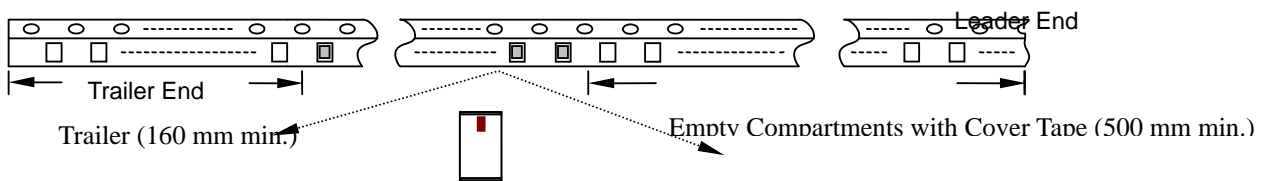

❖ **Peel-off Force**

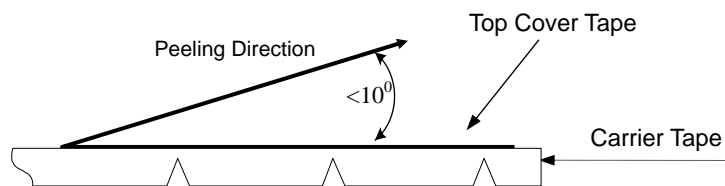

Peel-off force should be in the range of 0.2 – 1.20 N at a peel-off speed of 300 ± 10 mm/min .

❖ **Storage Conditions**

- (1) Temperature: $+5 \sim 35^{\circ}\text{C}$, relative humidity (RH): 45~75%.
- (2) Non-corrosive environment

Notes

❖ The contents of this data sheet are subject to change without notice. Please confirm the specifications and delivery conditions when placing your order.

Mechanical & Environmental Characteristics

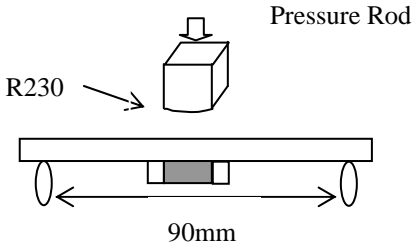
Item	Requirements	Procedure
Solderability	<ol style="list-style-type: none"> No apparent damage More than 95% of the terminal electrode shall be covered with new solder 	<ol style="list-style-type: none"> Preheat: $120 \pm 5^\circ\text{C}$ Solder: $245 \pm 5^\circ\text{C}$ for 5 ± 1 sec
Soldering strength (Termination Adhesion)	<ol style="list-style-type: none"> 10N minimum 	<ol style="list-style-type: none"> Solder specimen onto test jig. Apply push force at 0.5mm/s until electrode pads are peeled off or ceramic are broken. Pushing force is applied to longitude direction
Deflection (Substrate Bending)	<ol style="list-style-type: none"> No apparent damage 	<ol style="list-style-type: none"> Solder specimen onto test jig (FR4, 1.6mm) using the recommend soldering profile. Apply a bending force of 1 mm deflection. 
Heat/Humidity Resistance	<ol style="list-style-type: none"> No apparent damage Fulfill the electrical specification after test 	<ol style="list-style-type: none"> Temperature: $85 \pm 2^\circ\text{C}$ Humidity: 90% ~ 95% RH Duration: 1000 ± 48hrs Recovery: 1-2hrs
Thermal shock (Temperature Cycle)	<ol style="list-style-type: none"> No apparent damage Fulfill the electrical specification after test 	<ol style="list-style-type: none"> One cycle/step 1 : $125 \pm 5^\circ\text{C}$ for 30 min step 2 : $-40 \pm 5^\circ\text{C}$ for 30 min No of cycles : 100 Recovery: 1-2 hrs
Low Temperature Resistance	<ol style="list-style-type: none"> No apparent damage Fulfill the electrical specification after test 	<ol style="list-style-type: none"> Temperature: $-40 \pm 5^\circ\text{C}$ Duration: 500 ± 24hrs Recovery: 1-2hrs

Soldering Conditions

❖ Typical Soldering Profile for Lead-free Process

Reflow Soldering :

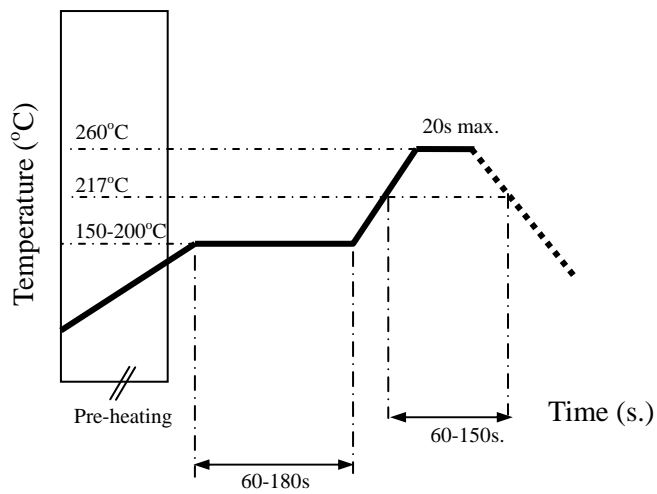

Notes

❖ The contents of this data sheet are subject to change without notice. Please confirm the specifications and delivery conditions when placing your order.

Advanced Ceramic X Corp.

16 Tzu Chiang Road, Hsinchu Industrial District Hsinchu Hsien 303, Taiwan

TEL:886-3-5987008 FAX:886-3-5987001

E-mail: acx@acxc.com.tw

<http://www.acxc.com.tw>